

**Robert Bosch GmbH**  
Power Tools Division  
70764 Leinfelden-Echterdingen  
GERMANY

[www.bosch-pt.com](http://www.bosch-pt.com)

**1 609 92A 0XZ** (2014.09) PS / 256 EURO



1 609 92A 0XZ

## GCD 12 JL Professional

 **BOSCH**

<b>de</b> Originalbetriebsanleitung	<b>tr</b> Orijinal işletme talimatı	<b>mk</b> Оригинално упатство за работа
<b>en</b> Original instructions	<b>pl</b> Instrukcja oryginalna	<b>sr</b> Originalno uputstvo za rad
<b>fr</b> Notice originale	<b>cs</b> Původní návod k používání	<b>sl</b> Izvirna navodila
<b>es</b> Manual original	<b>sk</b> Pôvodný návod na použitie	<b>hr</b> Originalne upute za rad
<b>pt</b> Manual original	<b>hu</b> Eredeti használati utasítás	<b>et</b> Algupärane kasutusjuhend
<b>it</b> Istruzioni originali	<b>ru</b> Оригинальное руководство по эксплуатации	<b>lv</b> Instrukcijas oriģinālvalodā
<b>nl</b> Oorspronkelijke gebruiksaanwijzing	<b>uk</b> Оригінальна інструкція з експлуатації	<b>lt</b> Originali instrukcija
<b>da</b> Original brugsanvisning	<b>kk</b> Пайдалану нұсқаулығының түпнұсқасы	<b>ar</b> تعليمات التشغيل الأصلية
<b>sv</b> Bruksanvisning i original	<b>ro</b> Instrucțiuni originale	<b>fa</b> دفترچه راهنمای اصلی
<b>no</b> Original driftsinstruks	<b>bg</b> Оригинална инструкция	
<b>fi</b> Alkuperäiset ohjeet		
<b>el</b> Πρωτότυπο οδηγιών χρήσης		



Deutsch .....	Seite	9
English .....	Page	17
Français .....	Page	24
Español .....	Página	33
Português.....	Página	41
Italiano .....	Página	49
Nederlands .....	Página	58
Dansk .....	Side	65
Svenska .....	Sida	73
Norsk .....	Side	80
Suomi .....	Sivu	87
Ελληνικά .....	Σελίδα	94
Türkçe .....	Sayfa	103
Polski .....	Strona	111
Česky .....	Strana	119
Slovensky.....	Strana	126
Magyar .....	Oldal	134
Русский .....	Страница	143
Українська.....	Сторінка	152
Қазақша.....	Бет	161
Română .....	Pagina	169
Български .....	Страница	177
Македонски .....	Страна	185
Srpski .....	Strana	194
Slovensko .....	Stran	201
Hrvatski .....	Stranica	208
Eesti .....	Lehekülj	216
Latviešu .....	Lappuse	223
Lietuviškai .....	Puslapis	231
عربي .....	صفحة	246
فارسی .....	صفحه	255

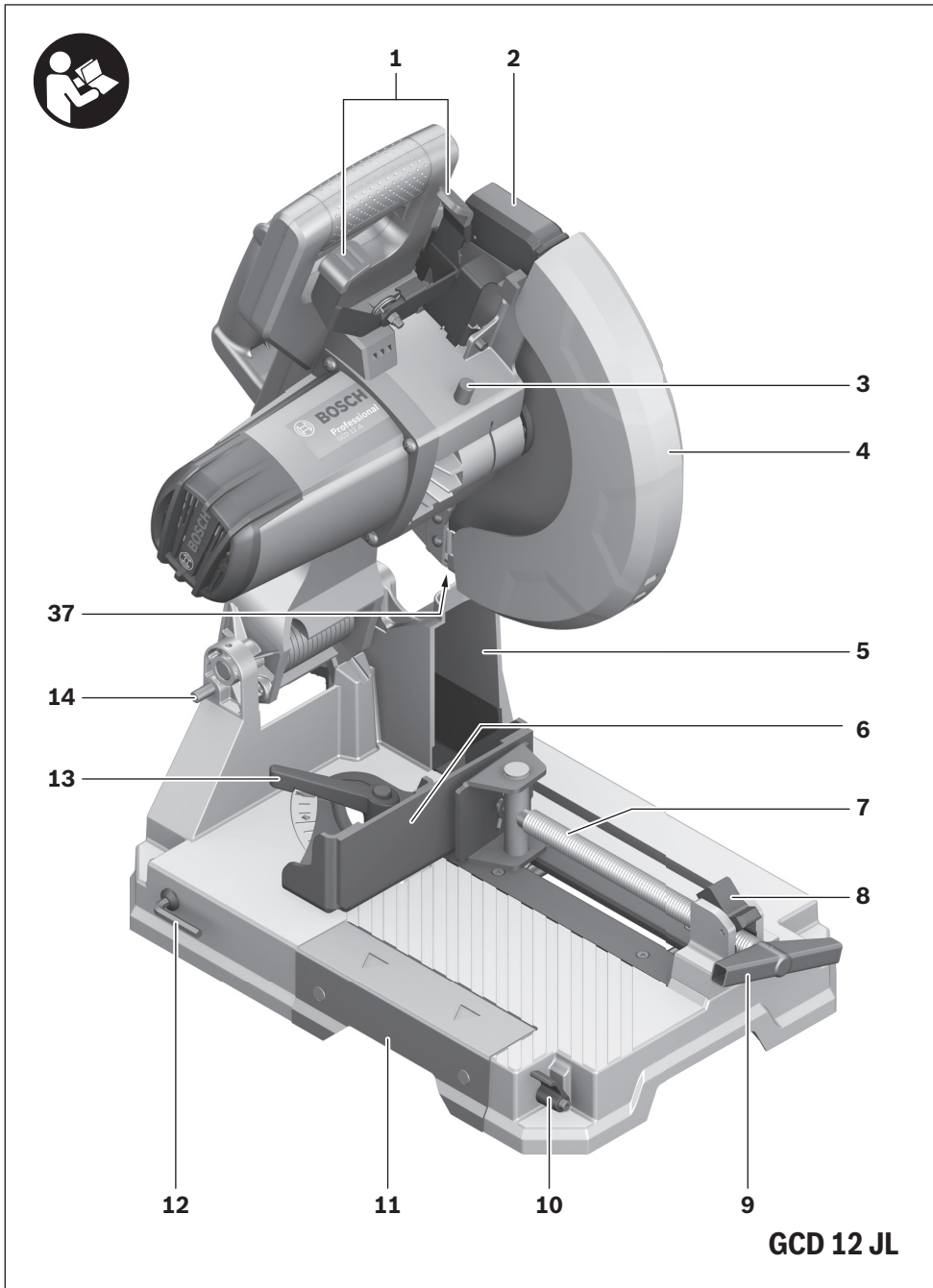

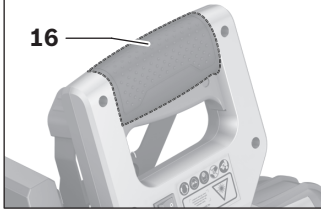
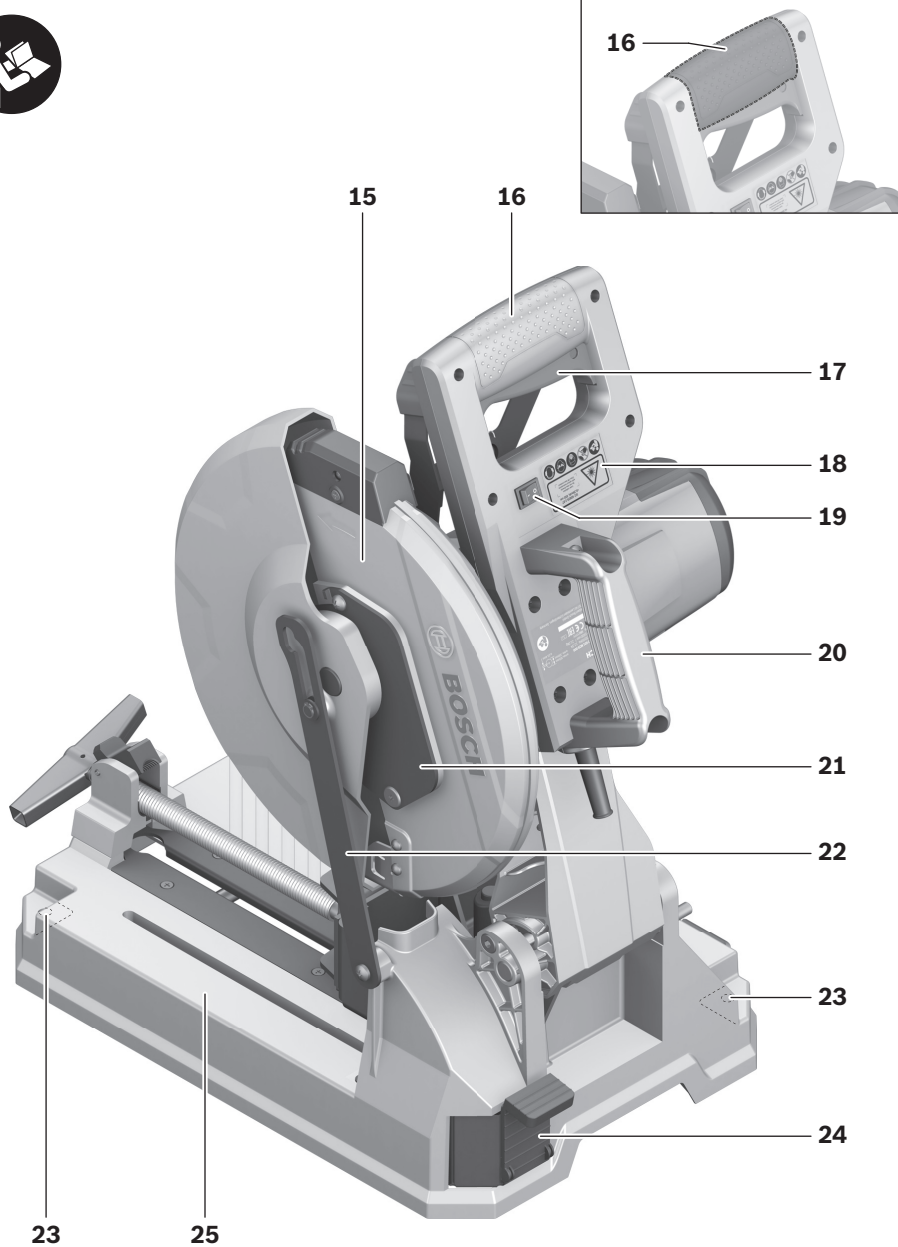

**GCD 12 JL**

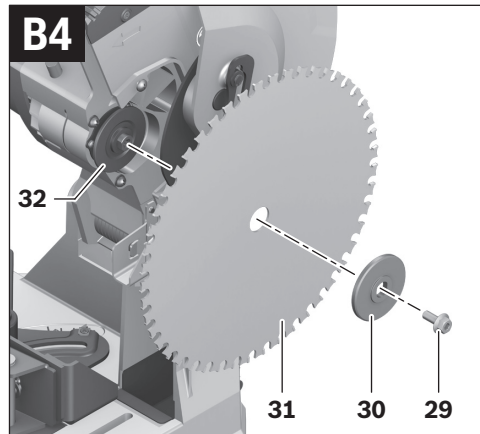
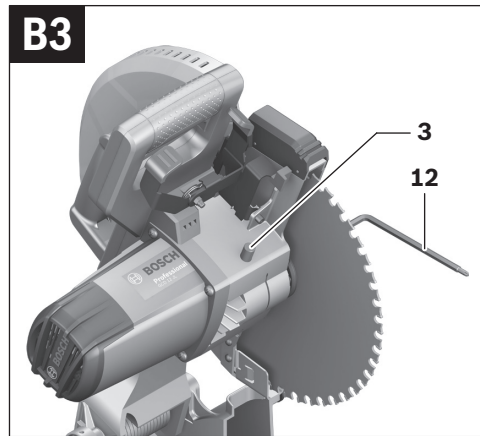
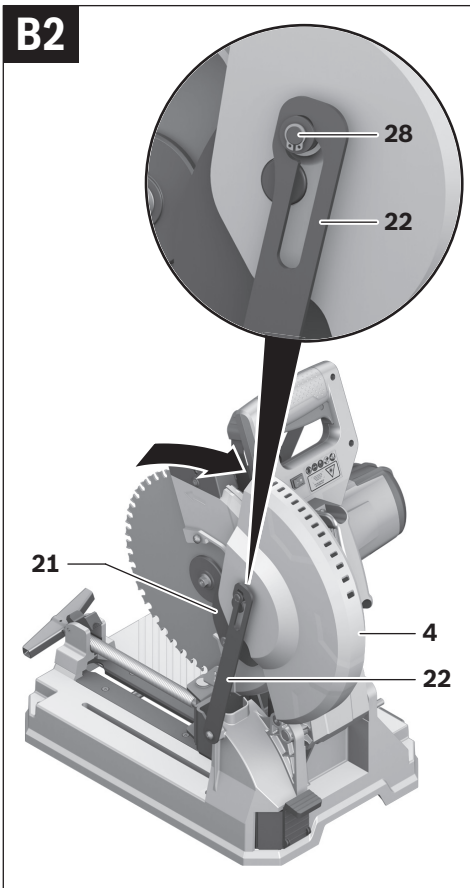
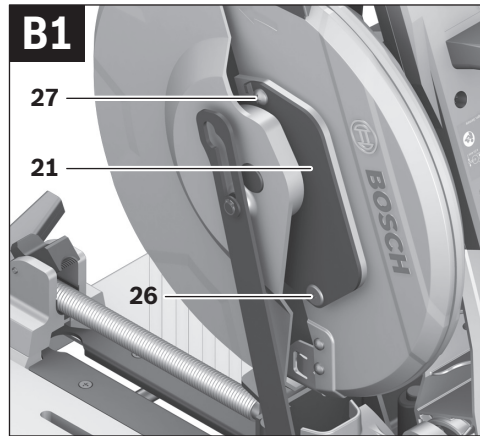
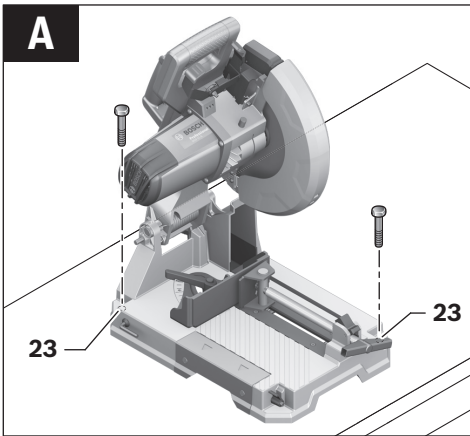

6 |

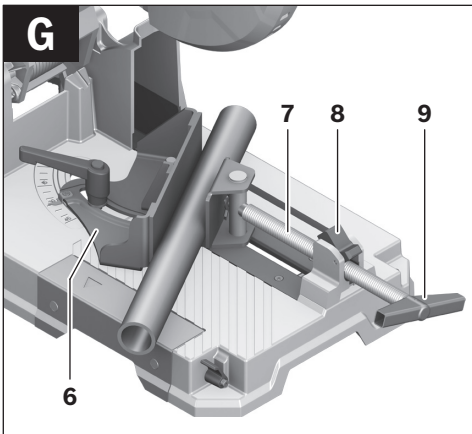
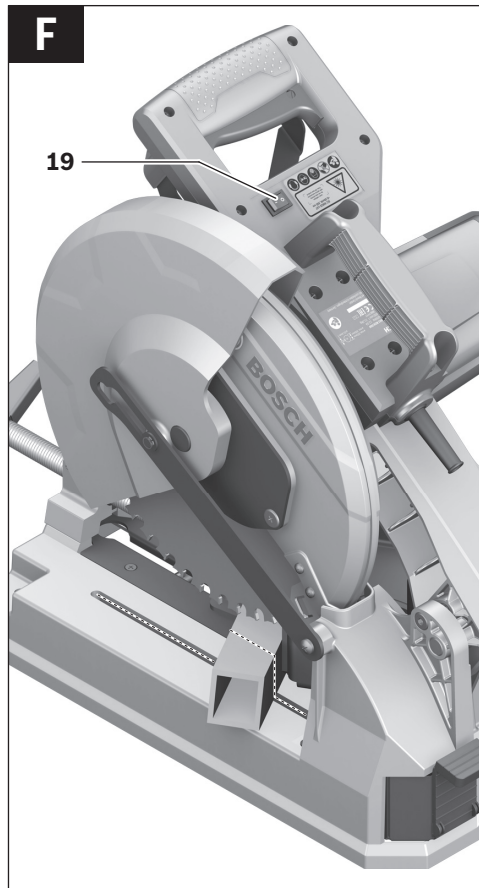
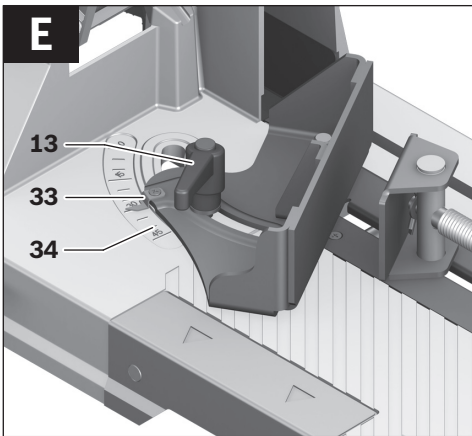
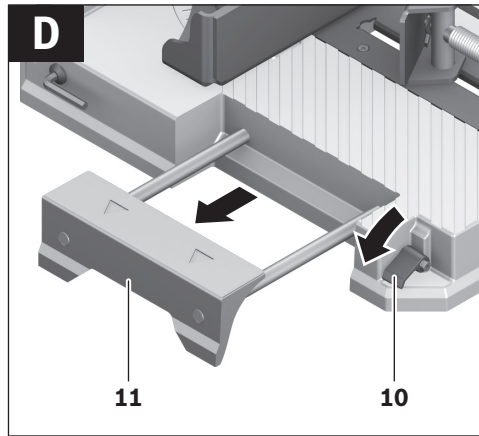
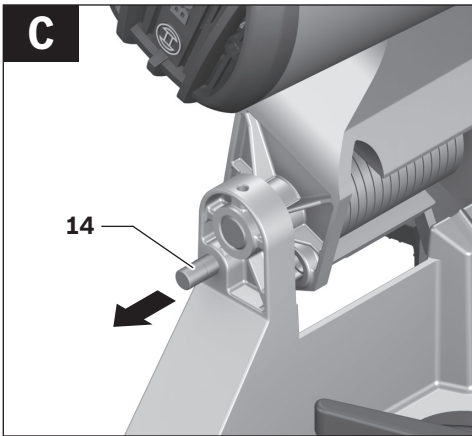

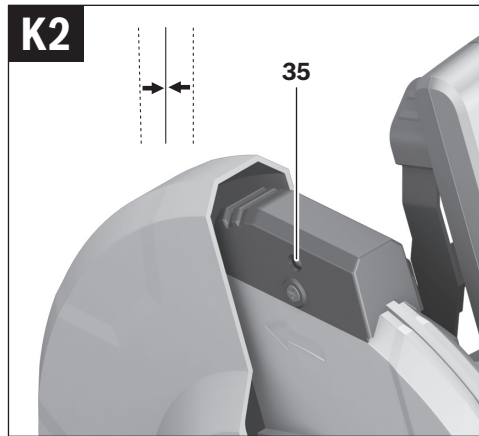
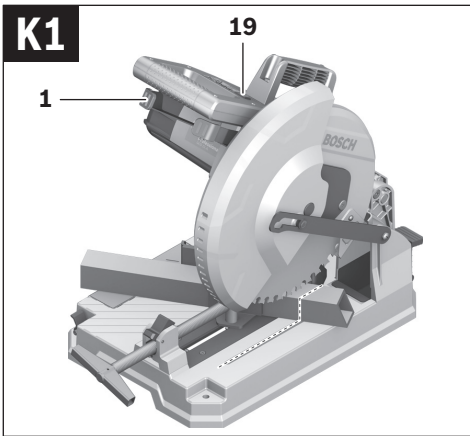
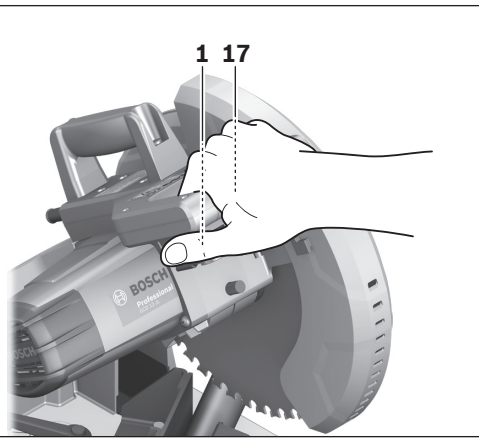
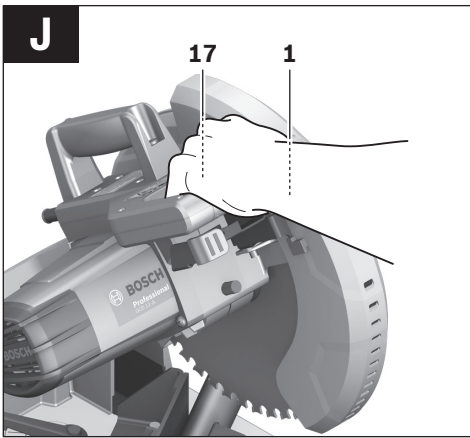
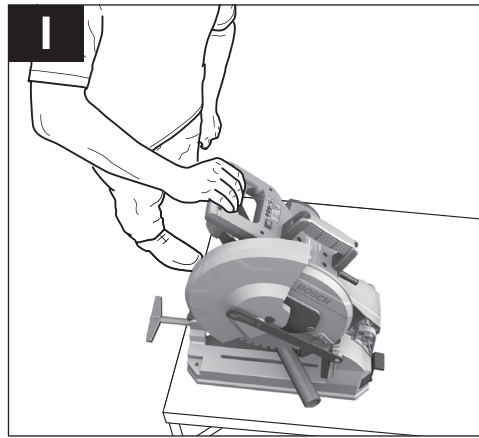
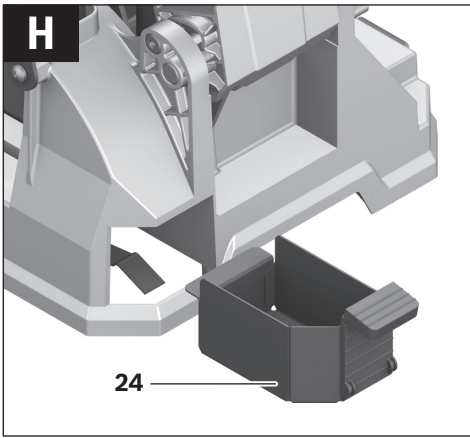

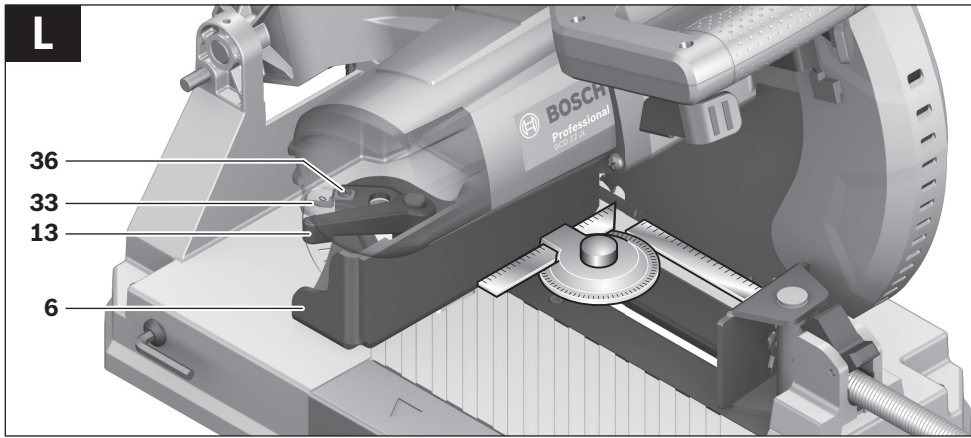

## English

### Safety Notes

#### General Power Tool Safety Warnings

**⚠ IMPORTANT** When using electric tools basic safety precautions should always be followed to reduce the risk of fire, electric shock and personal injury including the following.

**Read all these instructions before attempting to operate this product and save these instructions.**

The term "power tool" in the warnings refers to your mains-operated (corded) power tool or battery-operated (cordless) power tool.

#### Work area safety

- ▶ **Keep work area clean and well lit.** Cluttered or dark areas invite accidents.
- ▶ **Do not operate power tools in explosive atmospheres, such as in the presence of flammable liquids, gases or dust.** Power tools create sparks which may ignite the dust or fumes.
- ▶ **Keep children and bystanders away while operating a power tool.** Distractions can cause you to lose control.

#### Electrical safety

- ▶ **Power tool plugs must match the outlet. Never modify the plug in any way. Do not use any adapter plugs with earthed (grounded) power tools.** Unmodified plugs and matching outlets will reduce risk of electric shock.
- ▶ **Avoid body contact with earthed or grounded surfaces, such as pipes, radiators, ranges and refrigerators.** There is an increased risk of electric shock if your body is earthed or grounded.
- ▶ **Do not expose power tools to rain or wet conditions.** Water entering a power tool will increase the risk of electric shock.
- ▶ **Do not abuse the cord. Never use the cord for carrying, pulling or unplugging the power tool. Keep cord away from heat, oil, sharp edges and moving parts.** Damaged or entangled cords increase the risk of electric shock.
- ▶ **When operating a power tool outdoors, use an extension cord suitable for outdoor use.** Use of a cord suitable for outdoor use reduces the risk of electric shock.
- ▶ **If operating a power tool in a damp location is unavoidable, use a residual current device (RCD) protected supply.** Use of an RCD reduces the risk of electric shock.

#### Personal safety

- ▶ **Stay alert, watch what you are doing and use common sense when operating a power tool. Do not use a power tool while you are tired or under the influence of drugs, alcohol or medication.** A moment of inattention while operating power tools may result in serious personal injury.
- ▶ **Use personal protective equipment. Always wear eye protection.** Protective equipment such as dust mask, non-skid safety shoes, hard hat, or hearing protection

used for appropriate conditions will reduce personal injuries.

- ▶ **Prevent unintentional starting. Ensure the switch is in the off-position before connecting to power source and/or battery pack, picking up or carrying the tool.** Carrying power tools with your finger on the switch or energising power tools that have the switch on invites accidents.
- ▶ **Remove any adjusting key or wrench before turning the power tool on.** A wrench or a key left attached to a rotating part of the power tool may result in personal injury.
- ▶ **Do not overreach. Keep proper footing and balance at all times.** This enables better control of the power tool in unexpected situations.
- ▶ **Dress properly. Do not wear loose clothing or jewellery. Keep your hair, clothing and gloves away from moving parts.** Loose clothes, jewellery or long hair can be caught in moving parts.
- ▶ **If devices are provided for the connection of dust extraction and collection facilities, ensure these are connected and properly used.** Use of dust collection can reduce dust-related hazards.

#### Power tool use and care

- ▶ **Do not force the power tool. Use the correct power tool for your application.** The correct power tool will do the job better and safer at the rate for which it was designed.
- ▶ **Do not use the power tool if the switch does not turn it on and off.** Any power tool that cannot be controlled with the switch is dangerous and must be repaired.
- ▶ **Disconnect the plug from the power source and/or the battery pack from the power tool before making any adjustments, changing accessories, or storing power tools.** Such preventive safety measures reduce the risk of starting the power tool accidentally.
- ▶ **Store idle power tools out of the reach of children and do not allow persons unfamiliar with the power tool or these instructions to operate the power tool.** Power tools are dangerous in the hands of untrained users.
- ▶ **Maintain power tools. Check for misalignment or binding of moving parts, breakage of parts and any other condition that may affect the power tool's operation. If damaged, have the power tool repaired before use.** Many accidents are caused by poorly maintained power tools.
- ▶ **Keep cutting tools sharp and clean.** Properly maintained cutting tools with sharp cutting edges are less likely to bind and are easier to control.
- ▶ **Use the power tool, accessories and tool bits etc. in accordance with these instructions, taking into account the working conditions and the work to be performed.** Use of the power tool for operations different from those intended could result in a hazardous situation.

#### Service

- ▶ **Have your power tool serviced by a qualified repair person using only identical replacement parts.** This will ensure that the safety of the power tool is maintained.

## 18 | English

**Safety Warnings for Metal Cutting Saws**

- ▶ **The power tool is provided with a laser warning label (marked with number 18 in the representation of the power tool on the graphics page).**

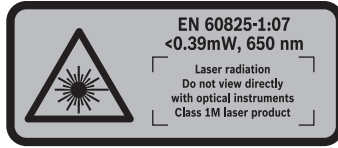

- ▶ **Never make warning signs on the machine unrecognisable.**
- ▶ **Do not make any modifications to the laser equipment.** The setting options described in these operating instructions can be used safely.
- ▶ **Never stand on the power tool.** Serious injuries can occur when the power tool tips over or when inadvertently coming into contact with the saw blade.
- ▶ **Make sure that the guard operates properly and that it can move freely.** Never lock the guard in place when opened.
- ▶ **Use the power tool only for dry cutting.** Water penetrating into a power tool increases the risk of an electric shock.
- ▶ **Never remove cutting remainders, metal chips, etc. from the cutting area while the machine is running.** Always guide the tool arm back to the neutral position first and then switch the machine off.
- ▶ **Guide the saw blade against the workpiece only when the machine is switched on.** Otherwise there is danger of kickback when the saw blade becomes wedged in the workpiece.
- ▶ **Keep the mains cable away from rotating application tools.** The mains cable can be cut through or get caught.
- ▶ **Keep handles dry, clean, and free from oil and grease.** Greasy, oily handles are slippery causing loss of control.
- ▶ **Operate the power tool only when the workpiece to be machined is the only thing on the work area. The area must be clear of any adjusting tools, metal swarf, etc.** Small pieces of metal or other objects that come into contact with the rotating saw blade can strike the operator with high speed.
- ▶ **Keep the floor free of metal swarf and material remnants.** You could slip or trip.
- ▶ **Always firmly clamp the piece to be worked. Do not saw workpieces that are too small to clamp.** Otherwise, the clearance of your hand to the rotating saw blade is too small.
- ▶ **Use the machine only for cutting the materials listed under Intended Use.** Otherwise, the machine can be subject to overload.
- ▶ **If the saw blade should become jammed, switch the machine off and hold the workpiece until the saw blade comes to a complete stop. To prevent kickback, the workpiece may not be moved until after the machine has come to a complete stop.** Correct the cause for the jamming of the saw blade before restarting the machine.

- ▶ **Do not use dull, cracked, bent or damaged saw blades.** Unsharpened or improperly set saw blades produce narrow kerf causing excessive friction, blade binding and kickback.
- ▶ **Always use blades with correct size and shape (diamond versus round) of arbour holes.** Blades that do not match the mounting hardware of the saw will run eccentrically, causing loss of control.
- ▶ **Do not use high speed steel (HSS) saw blades.** Such saw blades can easily break.
- ▶ **Do not touch the saw blade after working before it has cooled.** The saw blade becomes very hot while working.
- ▶ **Check the cable regularly and have a damaged cable repaired only through an authorised customer service agent for Bosch power tools. Replace damaged extension cables.** This will ensure that the safety of the power tool is maintained.
- ▶ **Store the machine in a safe manner when not being used. The storage location must be dry and lockable.** This prevents the machine from storage damage, and from being operated by untrained persons.
- ▶ **Do not direct the laser beam at persons or animals and do not stare into the laser beam yourself.** This power tool produces laser class 1M laser radiation according to EN 60825-1. Looking or viewing directly into the laser beam – especially with optical instruments such as binoculars etc. – can damage the eye.
- ▶ **Do not replace the installed laser with another laser type.** A laser that is not suitable for this power tool could pose dangers for other persons.
- ▶ **Secure the workpiece.** A workpiece clamped with clamping devices or in a vice is held more secure than by hand.
- ▶ **Never leave the machine before it has come to a complete stop.** Cutting tools that are still running can cause injuries.
- ▶ **Never use the machine with a damaged cable. Do not touch the damaged cable and pull the mains plug when the cable is damaged while working.** Damaged cables increase the risk of an electric shock.

**Products sold in GB only:** Your product is fitted with a BS 1363/A approved electric plug with internal fuse (ASTA approved to BS 1362).

If the plug is not suitable for your socket outlets, it should be cut off and an appropriate plug fitted in its place by an authorised customer service agent. The replacement plug should have the same fuse rating as the original plug.

The severed plug must be disposed of to avoid a possible shock hazard and should never be inserted into a mains socket elsewhere.

**Products sold in AUS and NZ only:** Use a residual current device (RCD) with a rated residual current of 30 mA or less.

## Symbols

The following symbols can be important for the operation of your power tool. Please memorise the symbols and their meanings. The correct interpretation of the symbols helps you operate the power tool better and more secure.

Symbol	Meaning
	<p>► <b>Laser radiation</b> Do not view directly with optical instruments Class 1M laser product</p>
	<p>► <b>Keep hands away from the cutting area while the machine is running.</b> Danger of injury when coming in contact with the saw blade.</p>
	<p>► <b>Wear ear protectors.</b> Exposure to noise can cause hearing loss.</p>
	<p>► <b>Wear safety goggles.</b></p>
	<p>► <b>Wear a dust respirator.</b></p>
	<p>Observe the dimensions of the saw blade. The hole diameter must match the tool spindle without play. Do not use reducers or adapters.</p>

## Product Description and Specifications



**Read all safety warnings and all instructions.** Failure to follow the warnings and instructions may result in electric shock, fire and/or serious injury.

### Intended Use

The machine is intended for stationary use with saw blades to perform lengthways and crossways straight cuts and miter angles to 45° in metal materials without the use of water.

## Product Features

The numbering of the components shown refers to the representation of the power tool on the graphic pages.

- 1 Locking lever
- 2 Laser protection cap
- 3 Spindle lock
- 4 Retracting blade guard
- 5 Chip box
- 6 Angle stop
- 7 Clamping spindle
- 8 Quick-release button
- 9 Spindle handle
- 10 Clamping lever of the saw-table extension
- 11 Saw-table extension
- 12 Hex key (size 6 mm)/cross-head screwdriver
- 13 Tension handle to lock the angle stop
- 14 Transport safety-lock
- 15 Blade guard
- 16 Handle
- 17 On/Off switch
- 18 Laser warning label
- 19 Laser on/off switch (for marking of cutting line)
- 20 Transport handle
- 21 Cover plate
- 22 Bracket
- 23 Mounting holes
- 24 Chip drawer
- 25 Saw table
- 26 Lower fastening screw (cover plate/retracting blade guard)
- 27 Upper fastening screw (cover plate/retracting blade guard)
- 28 Guide bolt
- 29 Hex socket screw (size 6 mm) for mounting of saw blade
- 30 Clamping flange
- 31 Saw blade
- 32 Interior clamping flange
- 33 Angle display
- 34 Scale for miter angles
- 35 Adjustment screw for laser position (parallelism)
- 36 Screw for angle display
- 37 Laser beam outlet

**Accessories shown or described are not part of the standard delivery scope of the product. A complete overview of accessories can be found in our accessories program.**

## 20 | English

**Technical Data**

Metal Cutting Saw	GCD 12 JL		
Article number		... 0..	... 060
3 601 M28 ...			
Rated power input	W	2000	1650
No-load speed	min <sup>-1</sup>	1500	1500
Soft starting		●	●
Laser type	nm	650	650
	mW	< 0.39	< 0.39
Laser class		1M	1M
Weight according to EPTA-Procedure 01/2003	kg	20	20
Protection class		□/II	□/II

Permissible workpiece dimensions (maximum/minimum) see page 22.

The values given are valid for a nominal voltage [U] of 230 V. For different voltages and models for specific countries, these values can vary.

**Dimension of suitable saw blades**

Saw blade diameter	mm	305
Blade body thickness	mm	1.8–2.5
Mounting hole diameter	mm	25.4

**Noise/Vibration Information**

Sound emission values determined according to EN 61029-2-10.

Typically the A-weighted noise levels of the product are:  
Sound pressure level 100 dB(A); Sound power level 113 dB(A). Uncertainty K = 3 dB.

**Wear hearing protection!**

Vibration total values  $a_h$  (triax vector sum) and uncertainty K determined according to EN 61029:  
 $a_h = 3.5 \text{ m/s}^2$ ,  $K = 1.5 \text{ m/s}^2$ .

The vibration emission level given in this information sheet has been measured in accordance with a standardised test given in EN 61029 and may be used to compare one tool with another. It may be used for a preliminary assessment of exposure.

The declared vibration emission level represents the main applications of the tool. However if the tool is used for different applications, with different accessories or poorly maintained, the vibration emission may differ. This may significantly increase the exposure level over the total working period.

An estimation of the level of exposure to vibration should also take into account the times when the tool is switched off or when it is running but not actually doing the job. This may significantly reduce the exposure level over the total working period.

Identify additional safety measures to protect the operator from the effects of vibration such as: maintain the tool and the accessories, keep the hands warm, organisation of work patterns.

**Declaration of Conformity** 

We declare under our sole responsibility that the product described under "Technical Data" is in conformity with all relevant provisions of the directives 2011/65/EU, 2014/30/EU, 2006/42/EC including their amendments and complies with the following standards: EN 61029-1, EN 61029-2-10, EN 60825-1.

Technical file (2006/42/EC) at:  
Robert Bosch GmbH, PT/ETM9,  
70764 Leinfelden-Echterdingen, GERMANY

Henk Becker                      Helmut Heinzelmann  
Executive Vice President      Head of Product Certification  
Engineering                      PT/ETM9

*PPA*  
 *i.v. Heinzelmann*

Robert Bosch GmbH, Power Tools Division  
70764 Leinfelden-Echterdingen, GERMANY  
Leinfelden, 03.09.2014

**Assembly**

- ▶ **Avoid unintentional starting of the machine. During assembly and for all work on the machine, the power plug must not be connected to the mains supply.**

**Delivery Scope**

Carefully remove all parts included in the delivery from their packaging.

Remove all packaging material from the machine and the accessories provided.

Before starting the operation of the machine for the first time, check if all parts listed below have been supplied:

- Metal cutting saw with mounted saw blade
- Hex key/cross-head screwdriver **12**

**Note:** Check the power tool for possible damage. Before further use of the machine, check that all protective devices are fully functional. Any lightly damaged parts must be carefully checked to ensure flawless operation of the tool. All parts must be properly mounted and all conditions fulfilled that ensure faultless operation.

Damaged protective devices and parts must be immediately replaced by an authorised service centre.

**Stationary or Flexible Mounting**

- ▶ **To ensure safe handling, the machine must be mounted on a level and stable surface (e. g., workbench) prior to using.**

**Mounting to a Working Surface (see figure A)**

- Fasten the power tool with suitable screw fasteners to the working surface. The mounting holes **23** serve for this purpose.

**Flexible Mounting (not recommended!)**

If, in exceptional circumstances, it is not possible to securely mount the power tool on a work surface, you can improvise by placing the feet of the saw-table **25** on an appropriate base (e.g. work bench, flat ground, etc.), without screwing down the power tool.

## Changing the Saw Blade (see figures B1 – B4)

- ▶ **Before any work on the machine itself, pull the mains plug.**
- ▶ **Actuate the spindle lock 3 only when the tool spindle is stopped.** Otherwise, the machine can become damaged.
- ▶ **When mounting the saw blade, wear protective gloves.** Danger of injury when touching the saw blade.

Use only saw blades whose maximum permitted speed is higher than the no-load speed of the power tool.

Use only saw blades that correspond with the characteristic data given in these operation instructions and that are tested and marked in accordance with EN 847-1.

Use only saw blades recommended by the tool manufacturer and suitable for sawing the materials to be cut.

### Removing the Saw Blade

- Bring the power tool into the working position. (see “Releasing the Machine (Working Position)”, page 21)
- Loosen the fastening screw **26** (approx. 2 turns) with the Phillips screwdriver **12**. Do not completely unscrew the screw.
- Loosen the fastening screw **27** (approx. 6 turns) with the Phillips screwdriver **12**. Do not completely unscrew the screw.
- Push the locking lever **1** and swing the retracting blade guard **4** upwards to the stop.
- Then pull back the retracting guard blade **4** and the cover plate **21** from the fastening screw **27** until the retracting guard blade is held by the guide bolt **28** in the bracket **22**.
- Turn the hex socket screw **29** with the hex key **12** provided while at the same time pressing the spindle lock **3** until it engages.
- Keep the spindle lock **3** pressed and unscrew the Allen screw **29** in anticlockwise direction.
- Remove the clamping flange **30**.
- Remove the saw blade **31**.

### Mounting the Saw Blade

If required, clean all parts to be mounted prior to assembly.

- Place the new saw blade onto the interior clamping flange **32**.
- ▶ **When mounting the saw blade, pay attention that the cutting direction of the teeth (arrow direction on the saw blade) corresponds with the direction of the arrow on the blade guard!**
- Put on the clamping flange **30** and the screw **29**. Press the spindle lock **3** until it engages and tighten the screw, turning in a clockwise direction.
- Loosen the spindle lock **3** again. If necessary, pull the knob by hand all the way up.
- Push the locking lever **1** and slide the retracting blade guard **4** and the cover plate **21** back under the fastening screw **27**.
- Slowly guide the retracting guard blade **4** downwards until the saw blade is completely covered again.
- Retighten the fastening screws **27** and **26**.

## Operation

- ▶ **Before any work on the machine itself, pull the mains plug.**

### Transport Safety (see figure C)

The transport safety-lock **14** enables easier handling of the machine when transporting to various working locations.

#### Releasing the Machine (Working Position)

- Push the tool arm by the handle **16** down a little in order to relieve the transport safety-lock **14**.
- Pull the transport safety-lock **14** completely outward.
- Guide the tool arm slowly upward.

**Note:** When working, pay attention that the transport safety-lock is not pushed inwards. Otherwise, the tool arm cannot be lowered to the requested depth.

#### Securing the Machine (Transport Position)

- Guide the tool arm downward until the transport safety-lock **14** can be pushed completely inward.

For additional information on transport, see page 23.

### Preparing for Operation

#### Extending the Saw Table (see figure D)

Long workpieces must be underlaid or supported at their free end.

The saw-table can be extended leftward using the saw-table extension **11**.

- Fold the clamping lever **10** downwards.
- Pull out the saw-table extension **11** to the desired length.
- To lock the saw-table extension, pull the clamping lever **10** back up.

#### Adjusting the Cutting Angle (see figure E)

The miter angle can be set in a range from 0° to 45°.

Frequently used mitre angles are identified on the angle stop **6** with appropriate markings. The 0° and 45° position are set at the respective end stop.

- Loosen the tension handle **13** of the angle stop **6**.
- Turn the angle stop **6** until the angle display **33** indicates the desired miter angle on the scale **34**.
- Retighten the tension handle **13**.

#### Marking the Cutting Line (see figure F)

A laser beam indicates the cutting line of the saw blade. This allows for exact positioning of the workpiece for sawing, without having to open the retracting blade guard.

- For this, switch the laser beam on with the switch **19**.
- Align the cutting mark on your workpiece with reference to the right-hand edge of the laser line.

**Note:** Before sawing, check if the cutting line is still indicated correctly (see “Adjusting the Laser”, page 23). The laser beam, as an example, can misadjust due to vibrations after intensive use.

## 22 | English

**Clamping the Workpiece (see figure G)**

To ensure optimum working safety, the workpiece must always be firmly clamped.

Do not saw workpieces that are too small to clamp.

Long workpieces must be underlaid or supported at their free end.

- Place the workpiece against the angle stop **6**.
- Slide the clamping spindle **7** against the workpiece and firmly clamp the workpiece with the spindle handle **9**.

**Loosening the Workpiece**

- Loosen the spindle handle **9**.
- Tilt up the quick release **8** and pull the clamping spindle **7** away from the workpiece.

**Working Advice****General Sawing Instructions**



Protect the saw blade against impact and shock. Do not subject the saw blade to lateral pressure.

Do not saw warped/bent workpieces. The workpiece must always have a straight edge to face against the fence.

Long workpieces must be underlaid or supported at their free end.

**Permissible Workpiece Dimensions**

**Maximum** workpiece sizes:

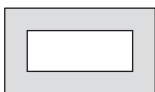
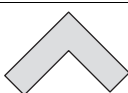
Workpiece Form	Mitre/Bevel Angle	
	0°	45°
	115 Ø	90 Ø
	100 x 100	85 x 85
	158 x 80	85 x 85
	110 x 110	85 x 85

**Minimum** workpiece sizes (= all workpieces that can be clamped via the clamping spindle **7**): Length 80 mm

**Cutting depth, max.** (0°/0°): 115 mm

**Dust- / Chip Disposal (see figure H)**

Dusts from materials such lead-containing coatings, minerals and metal can be harmful to one's health. Contact with or inhaling the dusts can trigger allergic reactions to the operator or bystanders and/or lead to respiratory infections.

Certain metal dusts are considered hazardous, especially in conjunction with alloys such as zinc, aluminium or chromium. Materials containing asbestos may only be worked by specialists.

- Provide for good ventilation of the working place.
- It is recommended to wear a P2 filter-class respirator.

Observe the relevant regulations in your country for the materials to be worked.

The saw blade **31** can become blocked by dust, chips or workpiece fragments in the slot of the saw table **25**.

- Switch the machine off and pull the mains plug from the socket outlet.
- Wait until the saw blade has come to a complete stop.
- Pull out the chip drawer **24** and empty if completely.

► **Prevent dust accumulation at the workplace.** Dusts can easily ignite.

**Starting Operation**

► **Observe the mains voltage!** The voltage of the power source must correspond with the data on the type plate of the machine.

**Position of the Operator (see figure I)**

► **Do not stand in a line with the saw blade in front of the machine. Always stand aside of the saw blade.** This protects your body against possible kickback.

- Keep hands, fingers and arms away from the rotating saw blade.
- Do not cross your arms when operating the tool arm.

**Switching On (see figure J)**

To save energy, only switch the power tool on when using it.

- To **start** the machine, press the On/Off switch **17** and keep it pressed.

**Note:** For safety reasons, the On/Off switch **17** cannot be locked; it must remain pressed during the entire operation.

The tool arm can be guided down only after pushing the locking lever **1**.

- For **sawing**, the locking lever **1** must be pushed in addition to pressing the On/Off switch.

**Soft starting**

The electronic soft starting feature limits the torque upon switching on and increases the working life of the motor.

**Switching Off**

- To **switch off** the machine, release the On/Off switch **17**.

**Sawing**

- Firmly clamp the workpiece as appropriate for its dimensions.
- Set the desired mitre angle.
- Switch on the machine.
- Push the locking lever **1** and guide the tool arm slowly downward with the tool handle **16**.
- Saw through the workpiece applying uniform feed.
- Switch off the machine and wait until the saw blade has come to a complete stop.
- Guide the tool arm slowly upward.

## Checking and Adjusting the Basic Adjustment

### ► Before any work on the machine itself, pull the mains plug.

To ensure precise cuts, the basic adjustment of the machine must be checked and adjusted as necessary after intensive use.

A certain level of experience and appropriate specialty tools are required for this.

A Bosch after-sales service station will handle this maintenance task quickly and reliably.

### Adjusting the Laser

**Note:** To test the laser function, the machine must be connected to power.

### ► While adjusting the laser (e. g. when moving the tool arm), never actuate the On/Off switch. Accidental starting of the power tool can lead to injuries.

- Bring the power tool into the working position.

**Checking:** (see figure K1)

- Draw a straight cutting line on the workpiece.
- Push the locking lever **1** and guide the tool arm slowly downward with the tool handle **16**.
- Align the workpiece in such a manner that the teeth of the saw blade are in alignment with the cutting line.
- Hold the workpiece in this position and slowly guide the tool arm upward again.
- Clamp the workpiece.
- Switch the laser beam on with switch **19**.

The laser beam must be in alignment with the cutting line on the workpiece over the complete length, also when the tool arm is lowered.

**Adjusting:** (see figure K2)

- Turn the adjustment screw **35** with the Phillips screwdriver **12** provided until the laser beam is parallel to the complete length of the cutting line on the workpiece.

One rotation in anticlockwise direction moves the laser beam from left to right; one rotation in clockwise direction moves the laser beam from right to left.

### Aligning the Angle Display (see figure L)

- Bring the machine into the transport position.
- Loosen the tension handle **13** of the angle stop **6**.
- Turn the angle stop **6** until the stop to the 0° position.

**Checking:**

- Adjust an angle gauge to 90° and position it between the angle stop **6** and the saw blade **31** on the saw-table **25**.

The leg of the angle gauge must be flush with the angle stop over the complete length.

**Adjusting:**

- Twist the angle stop **6** until the leg of the angle gauge is flush with the saw blade over the complete length.
- Retighten the tension handle **13**.
- Loosen the screw **36** with the Phillips screwdriver **12** provided and align the angle indicator along the 0° mark.
- Retighten the screw again.

## Transport

Before transporting the power tool, the following steps must be carried out:

- Bring the machine into the transport position.
- Remove all accessories that cannot be mounted firmly to the power tool.  
If possible, place unused saw blades in an enclosed container for transport.
- Always carry the power tool by its transport handle **20**.

### ► The power tool should always be carried by two persons in order to avoid back injuries.

### ► When transporting the power tool, use only the transport devices and never use the protective devices.

## Maintenance and Service

### Maintenance and Cleaning

### ► Before any work on the machine itself, pull the mains plug.

### ► Clean the ventilation slots of your power tool regularly with a soft brush. The motor fan draws dust into the housing, and a large accumulation of metal dust can lead to electrical hazards.

### ► In extreme conditions, always use dust extraction as far as possible. Blow out ventilation slots frequently and install a portable residual current device (PRCD). When working metals, conductive dust can settle in the interior of the power tool. The total insulation of the power tool can be impaired.

### ► Have maintenance and repair work performed only by qualified specialists. In this manner, it can be ensured that the safety of the power tool is maintained.

The retracting blade guard must always be able to move freely and retract automatically. Therefore, always keep the area around the retracting blade guard clean.

If the replacement of the supply cord is necessary, this has to be done by Bosch or an authorized Bosch service agent in order to avoid a safety hazard.

## Accessories

### Article number

### Saw blades for cuts in steel (not suitable for stainless steel and aluminum)

Saw blade 305 x 25.4 mm, 60 teeth	2 608 643 060
Saw blade 305 x 25.4 mm, 80 teeth	2 608 643 061

### After-sales Service and Application Service

In all correspondence and spare parts order, please always include the 10-digit article number given on the type plate of the machine.

Our after-sales service responds to your questions concerning maintenance and repair of your product as well as spare parts. Exploded views and information on spare parts can also be found under:

**www.bosch-pt.com**

**24 | Français**

Bosch's application service team will gladly answer questions concerning our products and their accessories.

**Great Britain**

Robert Bosch Ltd. (B.S.C.)  
P.O. Box 98  
Broadwater Park  
North Orbital Road  
Denham  
Uxbridge  
UB 9 5HJ

At [www.bosch-pt.co.uk](http://www.bosch-pt.co.uk) you can order spare parts or arrange the collection of a product in need of servicing or repair.

Tel. Service: (0844) 7360109  
E-Mail: [boschservicecentre@bosch.com](mailto:boschservicecentre@bosch.com)

**Ireland**

Origo Ltd.  
Unit 23 Magna Drive  
Magna Business Park  
City West  
Dublin 24  
Tel. Service: (01) 4666700  
Fax: (01) 4666888

**Australia, New Zealand and Pacific Islands**

Robert Bosch Australia Pty. Ltd.  
Power Tools  
Locked Bag 66  
Clayton South VIC 3169  
Customer Contact Center  
Inside Australia:  
Phone: (01300) 307044  
Fax: (01300) 307045  
Inside New Zealand:  
Phone: (0800) 543353  
Fax: (0800) 428570  
Outside AU and NZ:  
Phone: +61 3 95415555  
[www.bosch.com.au](http://www.bosch.com.au)

**Republic of South Africa**

**Customer service**  
Hotline: (011) 6519600

**Gauteng – BSC Service Centre**

35 Roper Street, New Centre  
Johannesburg  
Tel.: (011) 4939375  
Fax: (011) 4930126  
E-Mail: [bsctools@icon.co.za](mailto:bsctools@icon.co.za)

**KZN – BSC Service Centre**

Unit E, Almar Centre  
143 Crompton Street  
Pinetown  
Tel.: (031) 7012120  
Fax: (031) 7012446  
E-Mail: [bsc.dur@za.bosch.com](mailto:bsc.dur@za.bosch.com)

**Western Cape – BSC Service Centre**

Democracy Way, Prosperity Park  
Milnerton  
Tel.: (021) 5512577  
Fax: (021) 5513223  
E-Mail: [bsc@zsd.co.za](mailto:bsc@zsd.co.za)

**Bosch Headquarters**

Midrand, Gauteng  
Tel.: (011) 6519600  
Fax: (011) 6519880  
E-Mail: [rbsa-hq.pts@za.bosch.com](mailto:rbsa-hq.pts@za.bosch.com)

**Disposal**

The machine, accessories and packaging should be sorted for environmental-friendly recycling.

Do not dispose of power tools into household waste!

**Only for EC countries:**

According to the European Directive 2012/19/EU for Waste Electrical and Electronic Equipment and its implementation into national right, power tools that are no longer usable must be collected separately and disposed of in an environmentally correct manner.

Subject to change without notice.

**Français****Avertissements de sécurité****Avertissements de sécurité généraux pour l'outil**

**ATTENTION** Lors de l'utilisation d'outil électroporatif, respecter les instructions de sécurité fondamentales suivantes afin d'éviter les risques de choc électrique, de blessures et d'incendie.

**Lire toutes les consignes avant d'utiliser cet outil électroporatif et garder soigneusement les consignes de sécurité.**

Le terme « outil » dans les consignes de sécurité fait référence à votre outil électrique alimenté par le secteur (avec cordon d'alimentation) ou votre outil fonctionnant sur batterie (sans cordon d'alimentation).

**Sécurité de la zone de travail**

- ▶ **Conserver la zone de travail propre et bien éclairée.** Les zones en désordre ou sombres sont propices aux accidents.
- ▶ **Ne pas faire fonctionner les outils électriques en atmosphère explosive, par exemple en présence de liquides inflammables, de gaz ou de poussières.** Les outils électriques produisent des étincelles qui peuvent enflammer les poussières ou les fumées.
- ▶ **Maintenir les enfants et les personnes présentes à l'écart pendant l'utilisation de l'outil.** Les distractions peuvent vous faire perdre le contrôle de l'outil.